



Rail Accident Investigation Branch

Rail Accident Report



Runaway and collision at Armathwaite 28 January 2007

This investigation was carried out in accordance with:

- the Railway Safety Directive 2004/49/EC;
- the Railways and Transport Safety Act 2003; and
- the Railways (Accident Investigation and Reporting) Regulations 2005.

© Crown copyright 2008

You may re-use this document/publication (not including departmental or agency logos) free of charge in any format or medium. You must re-use it accurately and not in a misleading context. The material must be acknowledged as Crown copyright and you must give the title of the source publication. Where we have identified any third party copyright material you will need to obtain permission from the copyright holders concerned. This document/publication is also available at www.raib.gov.uk.

Any enquiries about this publication should be sent to:

RAIB	Email: enquiries@raib.gov.uk
The Wharf	Telephone: 01332 253300
Stores Road	Fax: 01332 253301
Derby UK	Website: www.raib.gov.uk
DE21 4BA	

This report is published by the Rail Accident Investigation Branch, Department for Transport.

This page is left intentionally blank

Runaway and collision at Armathwaite

28 January 2007

Contents

Introduction	6
Summary of the report	7
Key facts about the accident	7
Immediate cause, causal and contributory factors, observations	7
Recommendations	8
The Accident	9
Summary of the accident	9
Location	10
Trains and rail equipment	10
Events preceding the accident	12
Events during the accident	16
Consequences of the accident	16
Events following the accident	19
The Investigation	20
Investigation process	20
Sources of evidence	20
Factual Information	21
The derailment of the Kirow crane	21
Information provided by data recorders	21
Salmon wagon post-incident brake tests	22
Staff competence	23
Rule book requirements	23
EWS operating instructions and briefing	24
The planning of work	25
Previous occurrences of a similar character	26

Analysis	28
Identification of the immediate cause	28
Identification of casual and contributory factors	29
Severity of consequences	32
Conclusions	33
Immediate cause	33
Causal factors	33
Contributory factors	33
Actions reported as already taken or in progress relevant to this report	34
Recommendations	35
Recommendations to address causal and contributory factors	35
Appendices	36
Appendix A: Glossary of abbreviations and acronyms	36
Appendix B: Glossary of terms	37
Appendix C: Memorandum issued by First Engineering Ltd.	40

Introduction

- 1 The sole purpose of a Rail Accident Investigation Branch (RAIB) investigation is to prevent future accidents and incidents and improve railway safety.
- 2 The RAIB does not establish blame, liability or carry out prosecutions.
- 3 Access was freely given by First Engineering Ltd, Quattro Plant Ltd, Scotweld Employment Services Ltd, English Welsh & Scottish Railway (EWS) and Network Rail to their staff, data and records in connection with the investigation.
- 4 Appendices at the rear of this report contain the following glossaries:
 - acronyms and abbreviations are explained in Appendix A; and
 - technical terms (shown in *italics* the first time they appear in the report) are explained in Appendix B.
- 5 All mileage is measured from the zero point at London St Pancras.

Summary of the Report

Key facts about the accident

- 6 At about 14:15 hrs on Sunday 28 January 2007, a bogie flat wagon known as a salmon wagon ran away and collided with a *road-rail vehicle* (RRV) near Armathwaite, Cumbria.
- 7 The RRV was only superficially damaged, but the attached *thimble* that was being used to position new rail was broken. The salmon wagon derailed as a result of the collision but only minor damage was caused. The RRV operator was not injured, although he was shaken up as a result of the collision.
- 8 The collision followed an accident earlier in the day when a Kirow crane derailed.

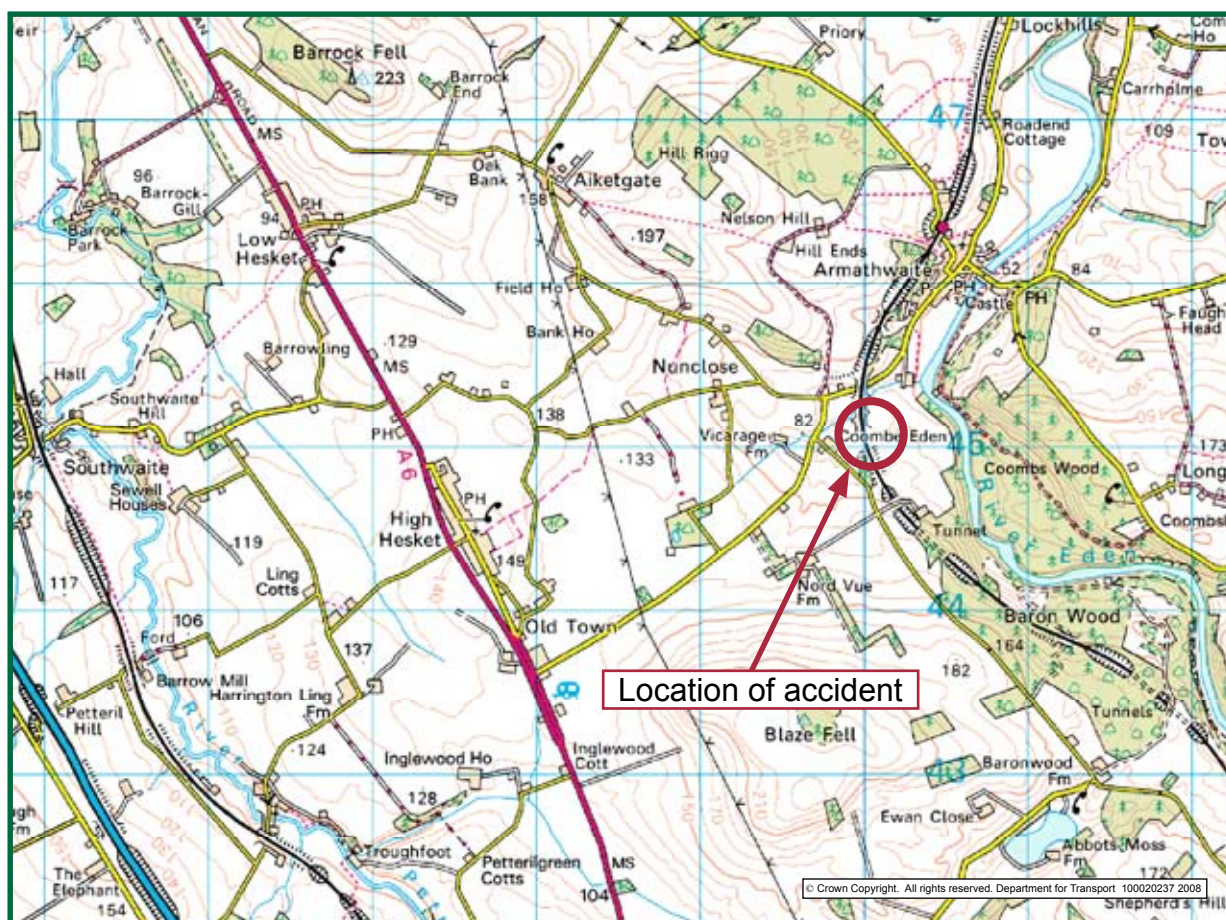

Figure 1: Extract from Ordnance Survey map showing location of accident

Immediate cause, causal and contributory factors, observations

- 9 The immediate cause of the accident was that the salmon wagon was not left secured on the gradient, and this led to its runaway and ultimate collision with the RRV after the air leaked off, releasing the wagon's brakes.
- 10 The causal factor of the accident was unauthorised First Engineering staff coupling and uncoupling vehicles who were neither trained in Module SS2 of the rule book (covering shunting) nor competent to do so. These actions were carried out despite there having been competent EWS staff available.

11 The contributory factors of the accident were:

- the *cant* compensator system fitted to the Kirow crane was too sensitive and caused spurious alarms to occur;
- the training given on the correct response to Kirow crane cant compensator alarms was inadequate;
- there was a miscommunication between the Engineering Supervisor and the Kirow crane crew which led to the Kirow crane crew misunderstanding what the plan was for the Kirow crane following its derailment and acting under their own volition; and
- the train driver did not apply the handbrakes to the salmon wagon when he left the locomotive and wagon unattended.

Recommendations

12 Recommendations can be found in paragraph 136. They relate to the following areas:

- the coupling and uncoupling of rail vehicles; and
- the training of operators of Kirow rail cranes to respond correctly to a cant compensator alarm.

The Accident

Summary of the accident

- 13 At about 14:15 hrs on Sunday 28 January 2007, a bogie flat wagon known as a salmon wagon ran away along the *down line* in the down direction near Armathwaite, Cumbria (Figure 1) and collided with a Case WX170 RRV positioning new rail with a thimble. This followed an accident earlier in the day, at 06:22 hrs, when a Kirow crane being used to lay new *sleepers* derailed.
- 14 The impact following the runaway caused the leading bogie of the salmon wagon to derail. There were no injuries, apart from the operator of the RRV being shaken up, and little resultant damage to either the salmon wagon or the RRV.
- 15 The accident occurred in an *engineer's work site* set up to renew 900 yds (823 metres) of the *up line* just south of Armathwaite station. The work site was in a *possession* of the line from Settle Junction to Petteril Bridge Junction, Carlisle (Figure 2). There were several other work sites within the possession which are not relevant to this accident.
- 16 The accident occurred on Network Rail's infrastructure.

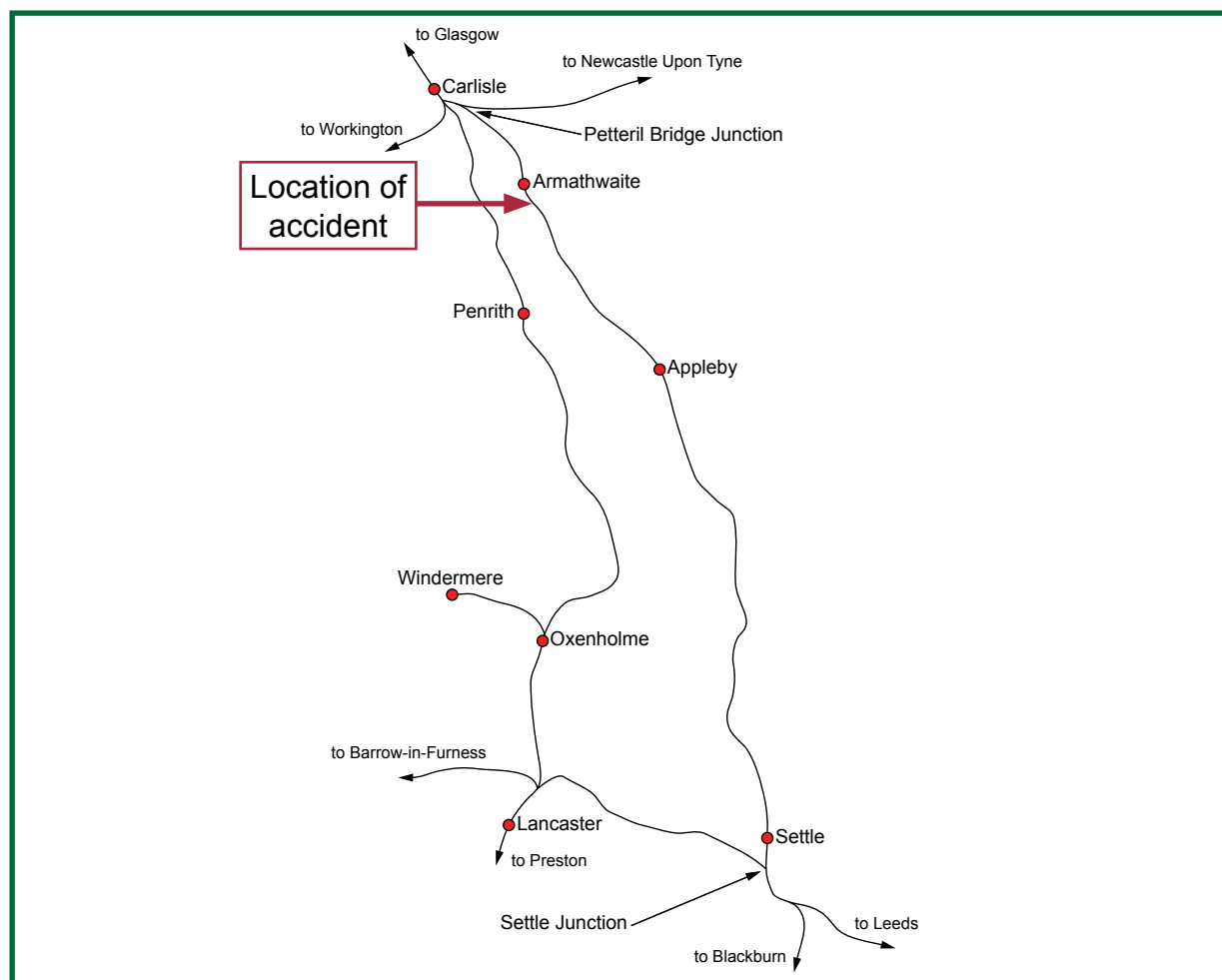

Figure 2: Diagram of the location

- 17 The work site in which the accident occurred was operated by First Engineering Ltd. The Kirow crane was owned by First Engineering Ltd and its joint venture partner Swietelsky Baugesellschaft mbH. It was operated at the work site by staff employed by Swietelsky or First Engineering. Swietelsky staff are managed within First Engineering as though directly employed.
- 18 The salmon wagon operating as part of the Kirow crane's normal consist was owned by EWS but leased to First Engineering.
- 19 Trains within the work site including train 6L62 which brought the Kirow crane formation to site were operated by EWS.
- 20 The RRV with which the runaway salmon wagon collided was owned by Quattro Plant Ltd and operated by one of their employees under the direction of a *machine controller*, employed by Scotweld Employment Services Ltd, working under contract to First Engineering Ltd.

Location

- 21 The collision occurred on the down line at the south end of Armathwaite viaduct at 297 miles 23 *chains*. This was just south of Armathwaite station (298 miles 9 chains) on the line which runs from Settle Junction at 234 miles 44 chains, to Petheril Bridge Junction, Carlisle, at 307 miles 12 chains. Figure 2 shows the location and Figure 3 is a view north from overbridge 319 towards Armathwaite viaduct.
- 22 Going south, the gradient of the line through Armathwaite station is a maximum of 1 in 217 falling, followed by a short section of level track at Armathwaite viaduct, followed by a rising gradient at a maximum of 1 in 155.

Trains and rail equipment

- 23 The Kirow KRC 250 rail crane, number DKR81623, used at the work site to lay concrete sleepers is a general purpose track renewals crane with a maximum lifting capacity of 25 tonnes at a radius of 10 metres without the *outriggers* deployed. It can run in train formation at up to 60 mph (96 km/h) and has a load carrying speed of up to 20 mph (32 km/h) when working free on rail (ie without outriggers deployed).
- 24 The crane was supplied in 2006 and certified by DeltaRail, a *vehicle acceptance body*, as being fit to run on Network Rail's infrastructure. A certificate was issued dated 1 November 2006.
- 25 A single match wagon accompanies the crane to provide storage for the lifting beam and any other materials required for working at site. Figure 4 shows the crane and its match wagon.
- 26 The purpose of the salmon wagon, which is coupled to the crane whenever it is in transit, is to reduce the loading produced by the crane on structures such as bridges that are under the railway. The resulting improvement in *route availability* increases the range of routes over which the crane can travel.
- 27 The salmon wagon is a bogie flat wagon with a *tare weight* of 24.84 tonnes that is normally used for carrying track panels to or from track renewals sites. At the time of the accident, the wagon in use for this purpose was numbered DB996308, and it was leased from EWS who were responsible for its maintenance. Figure 5 shows the salmon wagon.

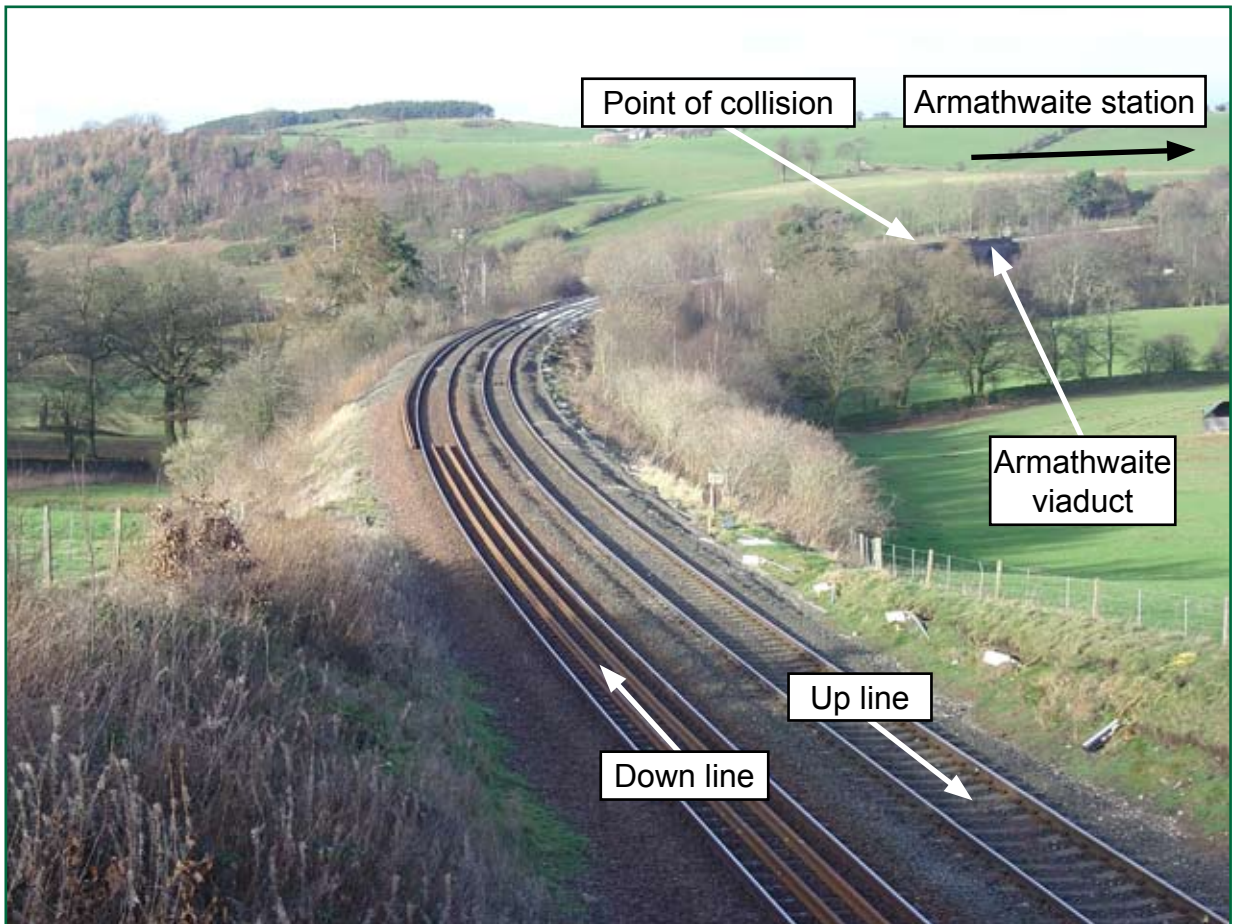

Figure 3: View north towards Armathwaite viaduct



Figure 4: Kirow crane DKR81623 and its match wagon



Figure 5: Salmon wagon DB996308

- 28 The normal running formation of the crane consists of three vehicles with the crane coupled between its match wagon and a salmon wagon. When the crane is working, it is uncoupled from the match wagon and from the salmon wagon.
- 29 The crane incorporates a compensator system for cants of up to 160 mm. This ensures that the crane superstructure and its load remain level despite changes in cant as the crane works free on rail.
- 30 The crane consist arrived in a train hauled by EWS class 66 locomotive number 66095, together with a train of wagons containing new ballast for the line that was to be relaid. The salmon wagon was subsequently uncoupled from the locomotive before the runaway occurred.
- 31 The RRV involved in the collision was a Case Poclairn WX170 excavator/crane, converted for operation on rail by Rexquote Ltd. It was numbered 251 in the fleet numbering system operated by Quattro Plant Ltd. Figure 6 shows the RRV.
- 32 Both the Kirow crane and the Case Poclairn WX170 RRV were classified as on-track plant (OTP) in the context of the railway rule book (*Railway Group Standard GE/RT8000*) applicable at the time of the accident. At the time of this report, the Kirow crane was classified as an on-track machine (OTM).

Events preceding the accident

- 33 The work being undertaken was to rerail, resleeper and reballast 900 yds (823 metres) of the up line south of Armathwaite station between 297 miles 213 yds and 297 miles 1113 yds. This was within an engineer's work site protected by *marker boards* placed at 293 miles 249 yds and 301 miles 440 yds. The work site was one of several within a possession of both up and down lines from Settle Junction to Petteril Bridge Junction. The possession was planned to start at 23:00 hrs on Friday 26 January 2007 but was started early at 22:33 hrs with the agreement of the signaller.



Figure 6: Case 170 RRV number 251

- 34 Train 6L62 conveying the Kirow crane consist and wagons of new ballast arrived from Carlisle at the work site on the down line at 00:34 hrs on Saturday 27 January 2007 and stopped north of Armathwaite station. EWS *groundstaff* uncoupled the crane formation at the south end of the train from the wagons of new ballast and then uncoupled the locomotive, 66095, and the salmon wagon from the crane. The locomotive and salmon wagon were to play no further part until the work was completed, so the locomotive hauled the salmon wagon to *overbridge* 319 at 296 miles 1681 yds. This was just south of where the work was being carried out, and at this location they were not in the way of the work taking place.
- 35 The crane was rigged for service with its lifting beam and uncoupled from its match wagon. The match wagon was left coupled to the south end of the wagons containing new ballast.
- 36 At 06:22 hrs on Sunday 28 February 2007, the crane derailed just north of Armathwaite viaduct. This was while it was lifting in new concrete sleepers and followed problems with the cant compensator system (see paragraph 58). Figure 7 shows the location of vehicles at the work site when the Kirow crane derailed.

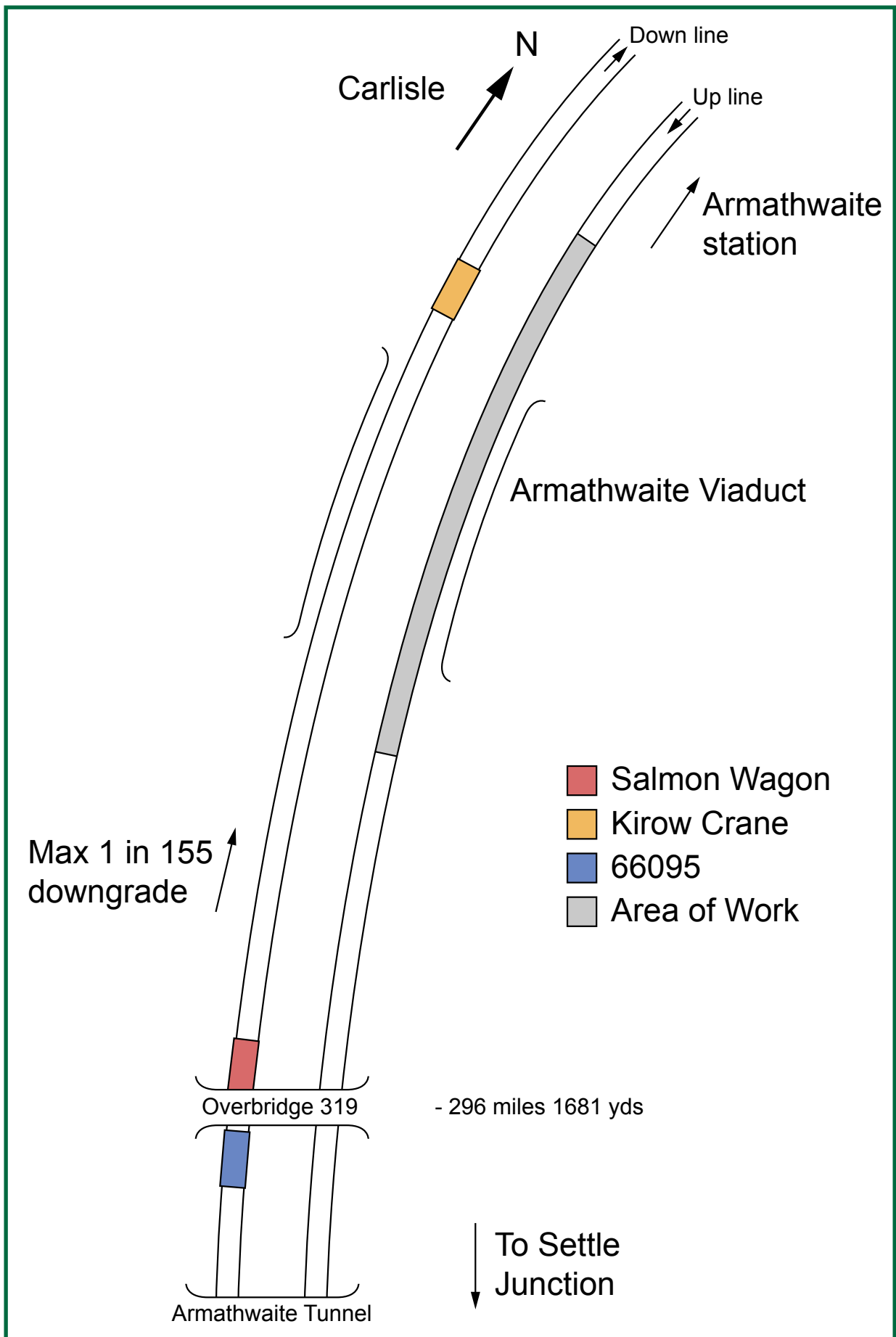

Figure 7: Location of vehicles at the worksite at the time the Kirow crane derailed

- 37 The crane was rerailed using its own equipment by about 09:20 hrs, but it was then found that it could not travel under its own power due to damage sustained in the derailment. Concluding that the crane was no longer fit for service and therefore in the way of the work taking place, the *engineering supervisor* arranged for locomotive 66095 to propel the salmon wagon from overbridge 319, couple up to the crane and then push the crane northwards to its match wagon and then leave the consist in a position where it could be inspected. However, when the salmon wagon buffered to the crane, the impact caused the crane's drive system to be restored, so the locomotive and salmon were no longer required to push it northwards. They returned close to their original position at overbridge 319.
- 38 The crane was then driven north at slow speed so that the lifting beam could be stowed on the match wagon and the crane inspected. It was coupled to the match wagon which was still coupled to the back of the train of wagons carrying new ballast. The assumption by the First Engineering staff at this time was still that the crane would not see further use for engineering work.
- 39 Discussions took place between the engineering supervisor, Kirow crane crew and local Network Rail staff at the site about what was to be done with the crane. The conclusion was that it would not be able to travel in train formation on the open railway due to the damage sustained. Staff at the site therefore decided that the crane would still be hauled off site that night in train 6L62, as planned, but it would then be detached into the sidings at Howe and Co's Sidings, about five miles north of Armathwaite. For a reason that has not been able to be ascertained, the Kirow crane crew gained the impression that because the crane was not fit to travel in train formation, it would instead need to be driven at slow speed to Howe and Co's Sidings under its own power, and after the work to relay the up line had been completed. This misunderstanding influenced the subsequent course of events.
- 40 By this time, a specialist engineer from First Engineering had inspected the crane and passed it fit for further movement, although it still required repairs to what in the event proved to be only minor damage (paragraph 61). As it was in the way of work taking place (the revised plan was to use RRVs to lay sleepers instead of the crane), the engineering supervisor decided that the crane should be driven to the salmon wagon and locomotive at overbridge 319. The engineering supervisor did not instruct the Kirow crane crew supervising and operating the crane to carry out any coupling to or uncoupling from other vehicles.
- 41 At 11:18 hrs, the crane, coupled to its match wagon on its north end, drove south with the *crane controller* riding on one of the seats (conflicting accounts were received as to which seat) outside the crane cab provided for this purpose. The crane arrived at the salmon wagon at overbridge 319 at 11:49 hrs. The crane was coupled to the salmon wagon, and the salmon wagon was uncoupled from the locomotive. Both these events took place at 11:52 hrs (paragraph 63). The crane was therefore marshalled into its travelling formation.
- 42 Just before the crane arrived at locomotive 66095, the driver left the locomotive, climbed up to the roadway, and then walked across bridge 319 and up the lane to get transport to Armathwaite station where he was to be relieved of duty. From the lane, he saw the crane approach the salmon wagon, saw a member of the crane crew jump down and signal to the crane operator to buffer the crane up to the salmon wagon and heard the sound of a coupling drop. The couplings and uncouplings referred to in paragraph 41 above therefore took place when the locomotive was unattended.

- 43 Before leaving locomotive 66095, the driver applied the *direct air brake* and the *parking brake*. The train brake connected through to the salmon wagon was left in a position where the normal *running pressure* of 5 bar in the *brake pipe* had been reduced to 4.4 bar resulting in a partial application of the brakes. The driver did not remove the locomotive key or lock the cab doors and applied neither of the two handbrakes on the salmon wagon as required by EWS instructions.
- 44 A few minutes later the First Engineering specialist engineer and another crane operator arrived at overbridge 319 on foot. At the same time, a First Engineering fitter, whose attendance had been arranged by the First Engineering specialist engineer, arrived from Glasgow with the parts necessary to repair the crane following its earlier derailment. Figure 8 shows the location of vehicles at the time the crane was under repair.
- 45 At around 12:50 hrs, the First Engineering specialist engineer advised the engineering supervisor that the crane had been repaired and was fit for further service. The crane was therefore uncoupled from the salmon wagon and the crane then driven back to where the work was taking place. After rigging the lifting beam and detaching the match wagon, the crane resumed lifting new sleepers into place.
- 46 The Case WX170 RRV then moved onto the down line at the south end of Armathwaite Viaduct at 297 miles 23 chains from its position where it had been parked just north of Armathwaite Viaduct. Its work was to place the new lengths of rail on the up line into position using a thimble and its location was between overbridge 319 and where the crane was working.

Events during the accident

- 47 At about 14:15 hrs, the salmon wagon ran away down the maximum 1 in 155 gradient for about 500 metres (547 yds) and collided with the RRV. Figure 9 shows the location of vehicles at the time the collision occurred.
- 48 The RRV operator in his cab saw the salmon wagon approaching and kept the foot brake pedal depressed to try and minimise the consequences of the collision.

Consequences of the accident

- 49 From both witness evidence and subsequent calculations carried out by the RAIB, the speed at impact is likely to have been around 27 km/h (17 mph).
- 50 The impact caused the leading bogie of the salmon wagon to derail and pushed the RRV back along the railway by about 3 metres (3.28 yds).
- 51 The RRV was only superficially damaged, but the thimble being used to position the new rail was broken. Minor damage was caused to the salmon wagon including a snapped off brake pipe *air cock* and lamp bracket, and bogie springs in the leading derailed bogie that had come out of position. Figure 10 shows the consequences of the collision.
- 52 The RRV operator who had remained in his cab, although not injured, was shaken up as a result of the collision.

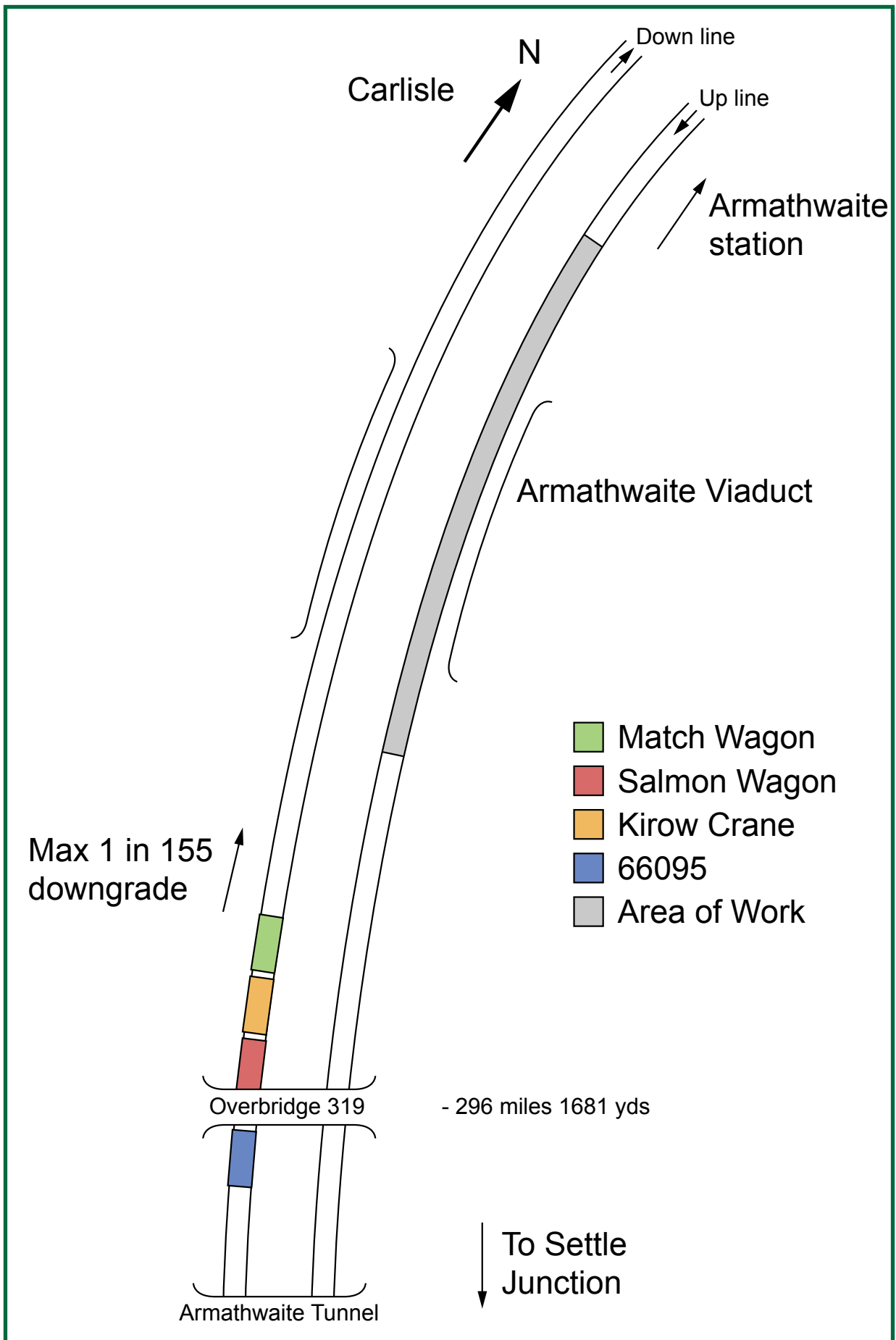

Figure 8: Location of vehicles at the time the crane was under repair

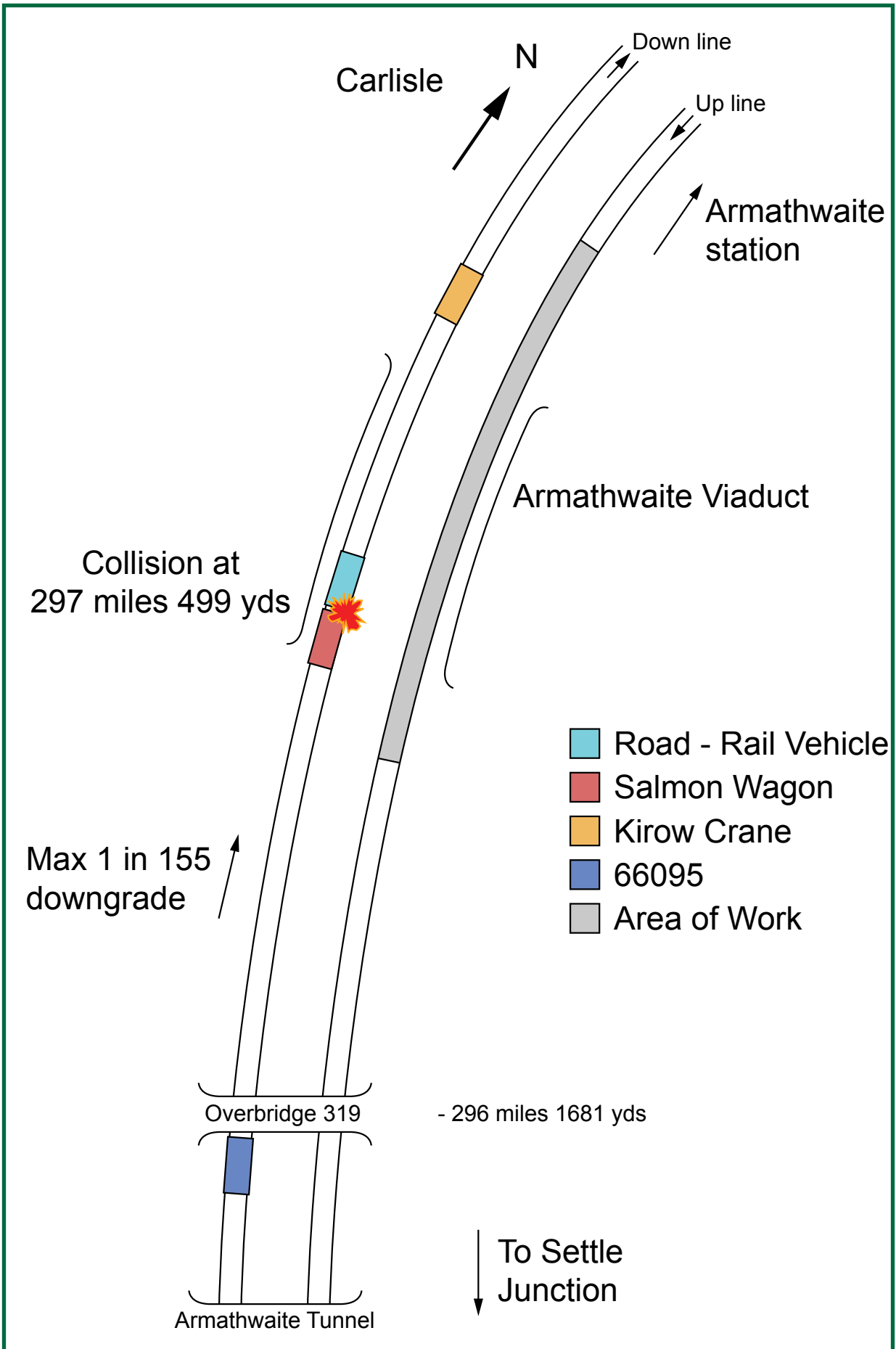

Figure 9: Location of the vehicles when the collision occurred



Figure 10: Consequences of the collision (by courtesy of Network Rail)

Events following the accident

- 53 Work carried on at the work site to complete the renewal of the planned section of up line.
- 54 The salmon wagon was railed by 20:07 hrs the same day, and temporary repairs were carried out so that it could travel with the Kirow crane in train 6L62 as planned. Train 6L62 left the work site for Carlisle Yard at 05:30 hrs on 29 January 2007.
- 55 The possession was eventually given up at 08:45 hrs on 29 January 2007, three hours later than its booked finish time. This was caused by delays arising from the derailment of the Kirow crane and the collision between the salmon wagon and the RRV.

The Investigation

Investigation process

56 The accident was reported to the RAIB by Network Rail shortly after it occurred at 14:46 hrs. The RAIB decided that an immediate deployment was not necessary, because there was no perishable evidence. The RAIB deployed inspectors the following day to carry out a site examination and commence interviewing witnesses.

Sources of evidence

57 Evidence considered in the investigation included the following:

- photographs and measurements taken where the collision occurred;
- marks on the track resulting from the collision;
- the condition of the vehicles involved in the accident;
- the results of the brake tests on the salmon wagon;
- witness statements;
- a download of locomotive 66095's *on train monitoring recorder* (OTMR);
- a download of the data recorder fitted to the Kirow crane;
- a report by First Engineering on the derailment of the Kirow crane on 28 January 2007;
- the railway rule book, GE/RT8000, and its requirements relating to shunting and the securing of vehicles;
- documentation relating to the planning of the work including the possession arrangements, the method statement and the Kirow crane lifting plan;
- EWS instructions relating to the stabling of vehicles; and
- reports on previous similar accidents.

Factual Information

The derailment of the Kirow crane

- 58 The Kirow crane derailed while it was carrying 28 concrete sleepers by means of a lifting beam. This occurred after there had been several instances where the cant compensator system had locked up causing the crane's emergency brake to apply and an alarm to indicate. A cant compensator alarm should occur if the bogies and the superstructure are failing to respond properly to changes in cant to keep the crane's superstructure level. Investigation since the derailment of the crane by First Engineering and Kirow found that the alarms were spurious and caused by the cant compensator transducer being too sensitive.
- 59 After the last alarm, the crane operator manually reset the cant compensator and levelled the crane. However, because the load was still on the hook and the jib was *slewed*, the bogies compensated differently for the cant and this led to uneven loading of the wheelsets. A lightly loaded wheel on the high side of the cant caused the crane to derail.
- 60 According to the Kirow training manual, if a cant compensator alarm occurs, the crane operator should lower the load to the ground and return the jib to its transport position, in line with the centre of the track. However, this issue had not been adequately covered in the training course attended by crane operators and delivered by Kirow, because there was no means of activating the alarm during training. This has since been rectified (paragraph 131).
- 61 The derailment of the crane caused only minor damage: two bolts securing the *keeper bracket* for the rearmost bogie sheared causing it to become detached; the speedometer sensor was damaged; and a leaf spring on the rear bogie was dislodged. This damage was repaired as described in paragraphs 44 – 45.

Information provided by data recorders

- 62 The data recorder fitted to the Kirow crane tracked the movement of the crane south to the salmon wagon at overbridge 319. It showed that the crane travelled between 11:18 hrs and 11:49 hrs. This latter time is considered to be when the crane reached the salmon wagon. The data recorder also showed that the crane stopped briefly for a few seconds before a final short movement took place. This provided further confirmatory evidence that the crane stopped just short of the salmon wagon prior to finally buffering up to it. This had been witnessed by the train driver from locomotive 66095 when he was walking along the lane from overbridge 319 to be relieved (paragraph 42).
- 63 The OTMR output from locomotive 66095 showed two spikes on the locomotive brake pipe pressure trace at 11:52:24 hrs and at 11:52:58 hrs (see Figure 11). These are indicative of the crane's brake pipe being connected to the salmon wagon's brake pipe followed 34 seconds later by the salmon wagon's brake pipe being disconnected from the locomotive. It can be concluded from this, that at these same times, the salmon wagon was being coupled to the crane and uncoupled from the locomotive. The time between the two spikes on the brake pipe pressure trace is consistent with the time it takes to walk from one end of a salmon wagon to the other.

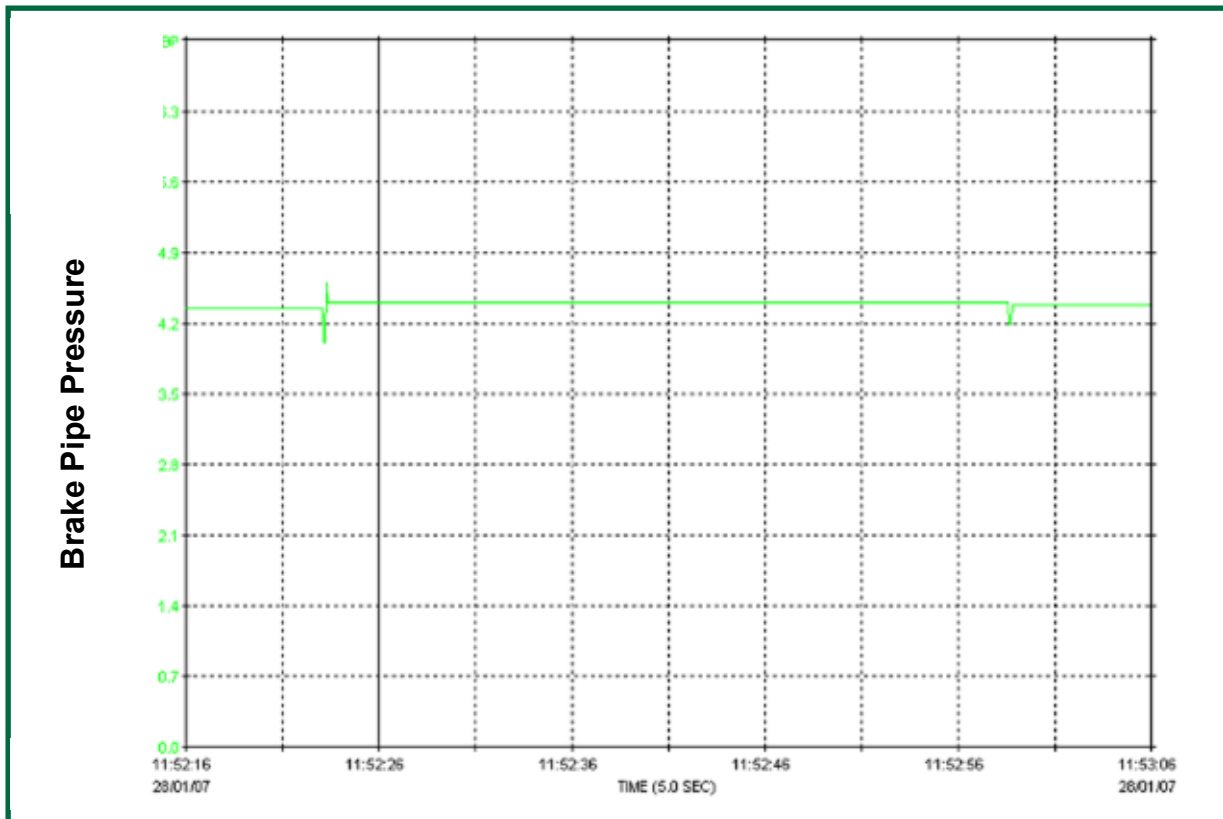

Figure 11: Extract from the download taken from the locomotive's OTMR

Salmon wagon post-incident brake tests

- 64 A diagram of the brake system fitted to the salmon wagon is shown in Figure 12. The wagon is *single piped* and the air brake pipe runs the length of the vehicle. When the pressure in the brake pipe is reduced, for example through the action of the train driver applying the train's brake, the *distributor* causes air to flow from the auxiliary reservoir to the brake cylinders to apply the brake with a force (dependent on the pressure admitted) which is proportional to the amount of reduction of pressure in the air brake pipe. This proportionality is achieved by the variation in pressure between the brake pipe pressure and the pressure in the *control reservoir* which is normally maintained constant at 5 bar by the locomotive.
- 65 In accordance with standard railway industry procedures, tests on the salmon wagon's braking system were undertaken by EWS at their depot at Carlisle Currock. These were to their standard EWS/ES/0097 'Brake Tests following an Incident'. The wagon passed all tests except distributor sensitivity, but this test was not relevant to the circumstances of the accident. Following discussions with the RAIB, EWS carried out tests to determine the rate of leakage from the wagon's brake cylinders. This was done by measuring the pressure remaining at half hourly intervals following the charging of the brake cylinders to full pressure (see paragraph 96 for the results of these tests).

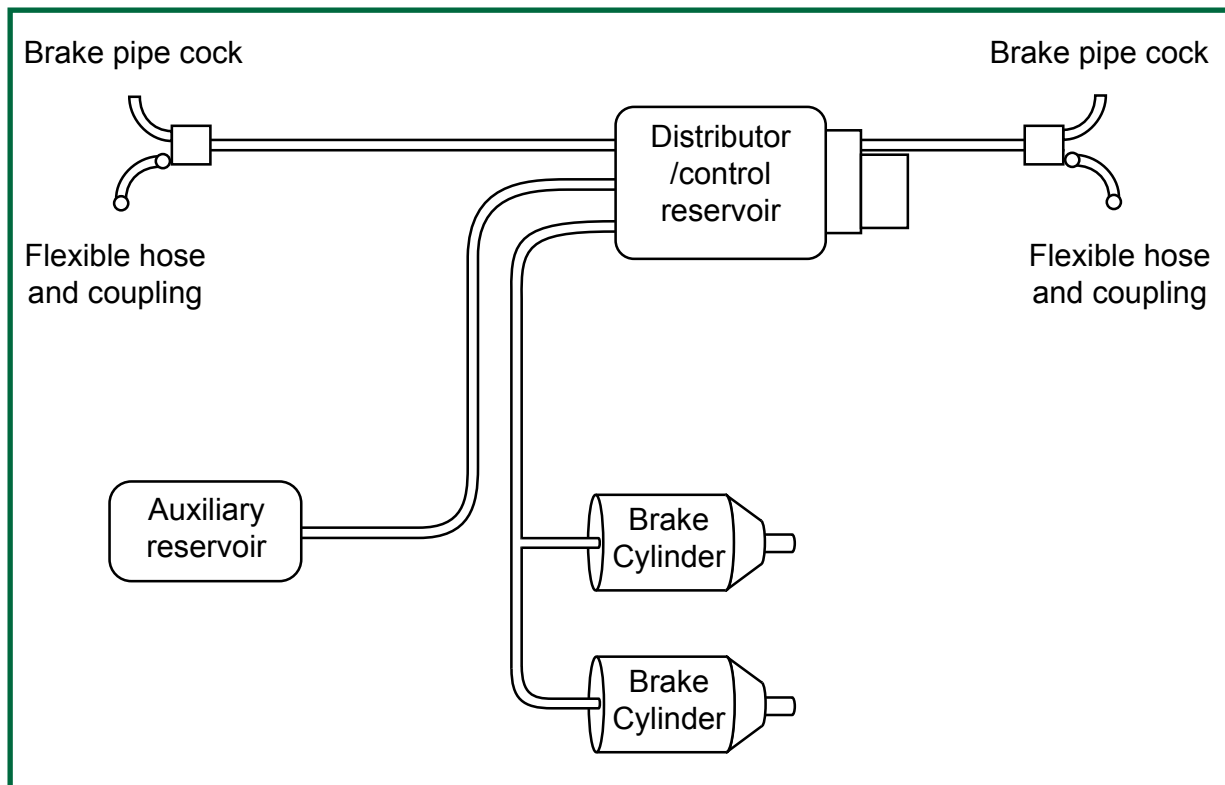

Figure 12: Salmon wagon braking system

Staff competence

- 66 The crane controller had a certificate of competence to undertake the supervision of crane lifting duties valid from 15 March 2006 to 1 May 2007. The crane operator who was driving the crane when it derailed and who also drove it to the salmon wagon was passed as competent in the operation of the Kirow KRC250 crane on 17 November 2006. The training on the Kirow crane included the coupling and uncoupling of the crane and its match wagon, but did not consider the use of the salmon wagon or rule book requirements relating to shunting vehicles.
- 67 The driver of the class 66 locomotive, 66095, was last assessed on the rules on 11 December 2006 and had a practical assessment on 17 November 2005. There were no issues of concern arising from these assessments. They were part of a two yearly cycle of competence reassessment. The driver had no previous history of *safety of the line* incidents.

Rule book requirements

- 68 Module OTP of the rule book GE/RT8000, covering on-track plant, required the appointment of both a machine controller and an operator when OTP was to be operated, unless the work required the operation of only one item of OTP in which case one person could carry out both roles. Machine controllers and operators were required to be competent in the rules contained in module OTP and in addition, a machine controller was required to be a certified *Controller of Site Safety* (COSS). Since a June 2007 update to module OTP, machine controllers must also be competent as a crane controller when controlling crane operations.

- 69 Module OTP of the rule book included on-track machines; other machines hauled by a train into a possession on their own wheels; RRVs; and rail-mounted maintenance machines brought to site and placed on the rails. It contained the rules necessary to ensure that on-track plant was operated safely. Since the rule book update in June 2007, module OTP no longer applies to on-track machines which are now covered by module OTM.
- 70 Module SS2 of the rule book covers shunting and section 7 relates to the attaching and detaching of vehicles. Clause 7.3 states that the *automatic air brake* must not be relied upon to secure a train or vehicles after detaching the locomotive and further states that before detaching a locomotive, the shunter must:
- apply enough handbrakes or *scotches* to secure the train;
 - apply them at the lower end of the train when it is on a gradient.
- Also, after detaching a vehicle from a train, the shunter must properly secure the vehicle by handbrake or scotches.
- 71 Module TW1 of the rule book covers the preparation and movement of trains (general) and clause 11.4 relates to leaving a traction unit, such as a locomotive, unattended. Under this clause, the driver is permitted to leave a traction unit unattended if it is to be handed over to another competent person who is to take charge of it. The driver is required to make sure the traction unit is properly secured before leaving it unattended so that it will not move.

EWS operating instructions and briefing

- 72 EWS issued *supplementary operating instructions* in December 2003. Section C6(g) covers train left unattended and the content relevant to the accident at Armathwaite states that when a driver needs to stable a train and no member of groundstaff is present he must:
- properly secure the traction unit(s);
 - apply the handbrakes on the three vehicles immediately next to the traction unit(s);
 - write the details of the number of handbrakes applied on the train document and leave it in a prominent position in the leading cab.
- 73 A traction unit is properly secured when both the direct air brake and the parking brake have been applied, and the automatic air brake applied to the full service position. The locomotive key should be removed and on a class 66 locomotive placed in the lockable cubicle between the number one end cab and the locomotive's clean air compartment.
- 74 Prior to the issue of the supplementary operating instructions relating to train left unattended, drivers were issued with written *Traction Digest Advice* number 83 that also contained the instructions. These were explained at a safety briefing which the driver of train 6L62 received at Warrington on 13 August 2003.
- 75 Despite the issued instructions, the driver considered that the salmon wagon was adequately held by the train air brake without the need to apply the salmon wagon handbrakes.

- 76 Also, following the runaway from a work site at Blake Street on 7 August 2005, EWS issued Traction Digest Advice number 124 dated 25 October 2005 to drivers, in line with the recommendation in the report on the accident, that drivers stabling locomotives detached from trains should draw clear of the trains by a specified minimum amount to prevent any adjacent vehicle from exerting a force on a stabled locomotive which could trigger movement. The Traction Digest Advice states that when drivers are required to detach a locomotive from a train and the locomotive is to be shut down and left unattended, the locomotive must be drawn two metres away from the vehicles. As no driver was present at the locomotive (paragraph 42) and the staff carrying out the uncoupling were neither trained nor authorised in EWS procedures (paragraph 66) this requirement was not complied with.
- 77 Following an incident at Warrington when a wagon with an ineffective handbrake subsequently moved after it was detached from a locomotive, EWS issued *Operating Digest Advice* number 119 dated 21 September 2005 to staff including groundstaff giving further instructions on the securing of vehicles. The instructions state that where the number of vehicles to be stabled is three or less, the shunter must conduct a pull test by instructing the driver to move away until he is satisfied that the stabled vehicles have been safely secured by handbrakes and will not move. Only then may the shunter carry out the uncoupling procedure.
- 78 To accord with this instruction, the three vehicles forming the crane consist should not have been uncoupled from the locomotive without a pull test having been carried out. Again, this requirement was not complied with, because no driver was present at the locomotive and the staff carrying out the uncoupling were neither trained nor authorised in EWS procedures (paragraph 66).

The planning of the work

- 79 Work at Armathwaite took place over three successive weekends, and the possession arrangements were planned starting with meetings six months before. The arrangements were finally published in the *Weekly Operating Notice* issued the week before the carrying out of the work. Person in charge of possession (PICOP) meetings were held on each Thursday before the weekend when the work was due to take place and a possession pack containing the detailed arrangements was issued. In the case of the work that took place over the weekend of 27/28 January 2007, the PICOP meeting was held in Appleby on 25 January 2007.
- 80 First Engineering plans the work it will carry out once it receives a specification from Network Rail. On the completion of detailed planning, and at least four weeks from when the work is due to be carried out, a method statement for the work is produced. This is written from a template because much of the content is repeated from one job to another. The method statement refers to risk assessments based on the hazards expected to exist at the site. These assessments are maintained separately for reference by the site access manager. The contents of the method statement should be briefed to staff by the site access manager when they book on duty at site in accordance with First Engineering's procedures.

- 81 For the work that took place at Armathwaite, the method statement was prepared by 30 November 2006 and approved on the same date. It was subsequently reviewed by Network Rail on 6 December 2006. The method statement did not specifically identify the gradient of the track, because it was not expected to cause a problem for the operation of any of the OTP. It was also considered that gradients can exist at any site and therefore did not require to be considered specially, given the capability of OTP to work on any gradient that could be encountered on the network.
- 82 The planning of the working of the Kirow crane was done separately from the method statement and formalised in a Kirow Crane Plan. Like the method statement, this was produced from a template but was not reviewed by Network Rail. The crane plan for the work at Armathwaite identified the maximum gradient and included site specific risk assessments. Risk/hazard reference 3.11 on the crane plan covered the runaway of the Kirow crane and match wagon due to incorrect working/securing. A simple assessment had been carried out with the risk to be controlled through the training and competence of crane manager, crane controllers and crane operators.
- 83 Risk/hazard reference 3.11 did not explicitly include the salmon wagon, but could be taken to do so if the salmon wagon was considered to be a 'match wagon'. However, the control measures failed to be effective, because the crane controller and crane operators were neither trained nor competent in all the requirements covering the uncoupling/coupling of vehicles and ensuring they were secure afterwards.
- 84 Crane controllers were required to complete a checklist before commencing lifting operations. This included a check that the method statement had been briefed to the crane operators and that a valid lifting plan had been prepared.

Previous occurrences of a similar character

- 85 Of all previous runaway occurrences during the previous twenty years, the runaway of a trailer wagon at Chorleywood on the Metropolitan Line of London Underground Ltd (LUL) on 16 May 1990 is probably of the greatest similarity to the runaway at Armathwaite.
- 86 A trailer wagon that had been detached from a contractor's tamping machine ran away down a falling gradient for approximately 1100 metres (1203 yds) and struck and killed four men before colliding with the tamping machine south of Chorleywood station.
- 87 The purpose of the trailer wagon was to ensure the reliable operation of track circuits when the tamping machine was being driven around the London Underground network. It weighed 17 tonnes and was equipped with a handbrake and a single *rail anchor*. It could also be braked by means of the train's automatic air brake.
- 88 The investigation by HM Railway Inspectorate found that the immediate cause of the accident was that neither the handbrake nor the rail anchor had been applied (and each on their own would have been sufficient to hold the wagon on the gradient) and that the automatic air brake had leaked off. Contributory factors were that the responsibility for coupling and uncoupling the trailer wagon was not properly defined, and there were no documented safe working practices concerning the tamping machine or its trailer.
- 89 Recommendations were made on LUL to improve the safety of systems of work; provide lamps at the each end of detached vehicles; consider the use of detonators or other audible warning devices at either side of work sites, and improve the means of communication to and from remote work sites.

- 90 In both the accidents at Chorleywood and Armathwaite, the tasks of coupling and uncoupling vehicles and making sure they were properly secured were not properly defined, so consequently they were carried out by staff who did not have the necessary training and competence.
- 91 Although for the work at Armathwaite the gradient was not considered during the overall planning of the work, it was covered in the Kirow crane plan (paragraph 82). It was also the case that no special measures were required to mitigate this hazard, given that all vehicles and plant used at the site were quite capable of being secured on the gradient concerned if this had been carried out correctly.
- 92 There have been other occurrences of vehicles running into worksites that are not of direct relevance to the accident at Armathwaite. Most incidents result from a combination of different causal and contributory factors. The RAIB is reviewing these incidents separately to see whether there are any common factors and, if so, what action can be taken to minimise the risk of runaways. The RAIB will put the findings of its review into the public domain.

Analysis

Identification of the immediate cause (refer Figure 12)

- 93 It was not possible to establish the pressure in the brake pipe of the crane when it arrived at the salmon wagon, but it is likely that it was at the normal running pressure of 5 bar. Once the crane had buffered up to the salmon wagon, the crane operator applied the crane's separate direct brake and the handbrake on the match wagon. The pressure at 5 bar was left in the brake pipe of the crane, but it was no longer being charged. When the brake pipe was connected between the crane and the salmon wagon, a small surge of pressure would have occurred before the locomotive equalised the pressure back to 4.4 bar again. This would explain the first spike (see Figure 11) on the locomotive's OTMR brake pressure trace which shows a momentary reduction in pressure immediately followed by a momentary increase (paragraph 63).
- 94 The second spike on the locomotive's OTMR brake pressure trace (see Figure 11) just shows a momentary reduction in pressure. This indicates that the brake pipe cocks between the locomotive and the salmon wagon were not closed at precisely the same time before uncoupling them resulted in a brief exhausting of air.
- 95 Therefore after the salmon wagon was uncoupled from the locomotive, there was a residual pressure of 4.4 bar in the brake pipe that had been delivered by the locomotive. At the same time, there would have been 5 bar of pressure (the normal running brake pressure) in the wagon distributor's control reservoir. Equalisation of these pressures causes the brakes to release.
- 96 The results of the brake tests on the salmon wagon (paragraph 65) showed that reducing the brake pipe pressure to 4.56 bar (equivalent to the 'initial' position of the train brake) resulted in brake cylinder pressures of 0.85 bar. The time taken for the cylinders to leak off from this pressure sufficiently to release the brake blocks from the wheels was between two and two and a half hours. Although the brake cylinder pressure would have been slightly higher than this (because the brake pipe pressure was actually reduced to 4.4 bar), once the salmon wagon was uncoupled from the locomotive (paragraph 41), the air in the brake cylinders leaked off in the period before it ran away (about 2 hrs 20 mins). This occurred while the crane was under repair, and subsequently when the salmon wagon was standing on the gradient uncoupled from any vehicle.
- 97 Neither of the two handbrakes had been applied to the salmon wagon, and no scotches had been fitted to the wheels. There was nothing to prevent the wagon running away once the air had leaked out of the brake cylinders. Therefore, the immediate cause of the accident was that the wagon had not been secured on the gradient. This led to its runaway and ultimate collision.
- 98 There is no evidence of deliberate intent on the part of those involved to leave the salmon wagon as an unattached vehicle. Following the repair of the Kirow crane and it being uncoupled from the salmon wagon (paragraph 45) in order to resume its work, the staff who had been present both when the salmon wagon was uncoupled from the locomotive (paragraph 41) and when the crane was uncoupled from the salmon wagon took no action to ensure the salmon wagon, standing uncoupled to any other rail vehicle, was secure.

Identification of causal and contributory factors

Causal factors

- 99 At 11:52 hrs, the Kirow crane was coupled to the salmon wagon which was uncoupled from locomotive 66095 at overbridge 319. By this time the locomotive driver was no longer present, and there was no resulting visual indication (such as the locomotive being stood off from the vehicles – see paragraph 76) that the locomotive was no longer attached (paragraph 41).
- 100 Following the repair of the Kirow crane (paragraph 45), First Engineering staff uncoupled the crane from the salmon wagon. They never considered that the salmon wagon might no longer at this stage be coupled to – and held by – locomotive 66095. Without examining the couplings, there was nothing to indicate otherwise.
- 101 Unqualified First Engineering staff carried out several instances of coupling and uncoupling of vehicles despite there being personnel provided by EWS for this purpose. These violations were not just carried out by ground level staff but extended to management, suggesting the practice was not just confined to the work site at Armathwaite.
- 102 Had EWS groundstaff carried out the coupling and uncoupling operations at overbridge 319, the crane consist would not have been left in a position to drive off site under its own power. The groundstaff took their instructions from the Engineering Supervisor who knew that the actual plan was to move the crane off site as part of train 6L62. There would have been no instruction given to uncouple the salmon wagon from locomotive 66095.
- 103 It is also unlikely, given the requirements to undertake a pull test and to leave an unattended locomotive standing clear of detached vehicles (paragraphs 76 and 77), that the groundstaff would in any case have uncoupled the salmon wagon from locomotive 66095 without the train driver being present.
- 104 Paragraphs 130 to 134 describe the action that First Engineering has taken since the accident to prevent further unauthorised coupling and uncoupling of rail vehicles at its work sites.
- 105 At Armathwaite, if the instructions that have since been issued by First Engineering had been followed (paragraph 133), competent EWS staff on duty would have been required to carry out any coupling or uncoupling of the crane consist or any of its elements (match wagon, crane or salmon wagon) to or from any locomotive or other wagons. First Engineering staff would have been instructed, and therefore should have known, that they were not authorised to do this.
- 106 The causal factor of the accident was unauthorised First Engineering staff coupling and uncoupling vehicles despite there having been competent EWS staff available. This can only be explained by a desire to speed the progress of the work; particularly as it was running behind schedule because of the earlier derailment of the Kirow crane.

Contributory factors

- 107 The Kirow crane derailed because of a lightly loaded wheel on the high side of canted track (paragraph 59). This was caused because the crane operator incorrectly reset the cant compensator leading to the derailment of the crane. The crane operator had experienced several cant compensator alarms during the work which were spurious and caused by the cant compensator system being too sensitive. This is therefore a contributory factor.

- 108 The correct response to a cant compensator alarm had not been covered properly during training (paragraph 60). This is the causal factor for the Kirow crane derailing. It is also a contributory factor to the runaway of the salmon wagon. Had the Kirow crane not derailed, the sequence of events that led to the coupling and uncoupling of vehicles at overbridge 319 would not have occurred in the way that it did.
- 109 First Engineering staff supervising and operating the Kirow crane gained the erroneous impression, following its derailment, that because it was thought it would not be able to travel on the open railway in train formation it would have to be driven off site under its own power, following the completion of the track renewal work (paragraph 39). This thinking almost certainly influenced the actions of the crane controller and the crane operator when the crane was driven to overbridge 319, and which led to the crane consist being made ready to be driven off site to save time later. The miscommunication between the Engineering Supervisor and the Kirow crane crew led to the Kirow crane crew misunderstanding what the plan was for the Kirow crane and then acting under their own volition. This is a contributory factor.
- 110 The driver of locomotive 66095 left the locomotive and wagon unattended without applying the salmon wagon handbrakes. This was despite EWS instructions to apply wagon handbrakes when stabling a train (paragraph 72). These had been explained to the driver at a safety briefing and the instructions issued in a Traction Digest Advice (paragraph 74). The driver believed that the salmon wagon was adequately braked through the locomotive's braking system and there was no need to apply handbrakes to the salmon wagon. The driver's action in not applying the handbrakes to the salmon wagon is a contributory factor.

Mitigating the effects of runaway vehicles

- 111 Runaways should be prevented if railway personnel carry out the correct procedures for the stabling of vehicles as laid down in section SS2 of the rule book (paragraph 70) and other local company procedures (paragraphs 72 to 78).
- 112 The Railway Group Standards (RGS) and associated code of practice described in paragraphs 113 to 117 below were mandatory. By the time of this report, RSSB had withdrawn them as part of their strategy to restrict mandatory RGSs to those that contain measures that only affect more than one dutyholder. In the place of these particular RGSs, the RSSB has published Rail Industry Standards (RIS) which are voluntary.
- 113 RGS GM/RT1403 (replaced by RIS-1700-PLT, 'Rail Industry Standard for Safe Use of Plant for Infrastructure Work' on 2 June 2007) covered the use of plant and work equipment. Clause 8.2.13 dealt with working on gradients and cants and required that the capability of plant for working safely on a gradient or on canted track should be assessed and a safe system of work developed to eliminate that risk. This clause was perpetuated in RIS-1700-PLT.
- 114 Guidance was given in Railway Group code of practice GM/RC1503 (also now replaced by RIS-1700-PLT on 2 June 2007). Clause 5.2.1 stated that the crane controller should have documented information defining the upper and lower gradient limits for the operation of the specific crane to be used. This information was to include such matters as when additional braking capability was required, when additional precautions were to be put in place and where the effect of the formation of the vehicles was relevant. These matters are covered in RIS-1700-PLT, under section 3.3, which gives guidance to produce a documented lift plan for every lifting operation.

- 115 A diagram was provided in GM/RC1503 showing a non-mandatory example of a gradient limit restriction sheet for a crane with brakes that were insufficient for the gradient. This showed that for the crane to work under its own power on a gradient of between 1 in 260 and 1 in 150 protection was required below the crane, consisting either of a train or locomotive, or of a timber baulk and *rail slippers* provided on each rail at a distance from the crane depending on the gradient. The timber baulk was to be downhill of the rail slippers. The working of the crane under its own power on a gradient steeper than 1 in 150 was forbidden.
- 116 The protection mentioned in paragraph 115 was required for older cranes rather than modern braked ones and was to mitigate the consequences of the crane running away, as opposed to the protection of a crane (such as the RRV with which the salmon wagon collided at Armathwaite) from other runaway vehicles. The example was not carried forward into RIS-1700-PLT and thus no longer features in any standards or associated guidance
- 117 RGS GM/RT1300 was replaced by RIS-1530-PLT in April 2006 and covered the engineering acceptance of RRVs and associated equipment working on the railway. It required a vehicle to be able to travel or work on a 1 in 29 gradient (carried forward into RIS-1530-PLT). There is nowhere steeper than this on the national railway network.
- 118 The measures specified in paragraph 115 above were therefore no longer required by standard where plant (such as that in use at Armathwaite) could meet the requirement to work safely on a gradient at up to 1 in 29 (the Kirow crane can work on a 1 in 25 gradient).
- 119 The use of a physical means such as a timber baulk or other derailing device to stop a runaway vehicle could lead to an overall increase in the risk to system safety. Procedures would be required to cover the removal of such physical barriers, otherwise a service train could hit a baulk and derail, with potentially catastrophic consequences.
- 120 Although, with detailed management attention, the correct performance of such procedures could be achieved to a high level, there would inevitably be the occasional instances where they were not, caused by human error, and consequently a line under possession might be reopened to traffic with an obstruction still in place across the rails.
- 121 Evidence supporting this possibility is provided by the number of occasions on the national network when protection associated with possessions (eg *possession limit boards* and *detonators*) is either put in the wrong place (such as a line still open to traffic), or is not removed afterwards. The RAIB looked at four random months since February 2005 and found 25 instances where protection had been put in the wrong place and 15 instances where not all the protection had been removed afterwards. These events happen despite there being a formal system for confirming the placing and removal of such protection by verbal assurance from the staff responsible for placing and removing the protection to the PICOP.
- 122 Physical protection to derail runaway vehicles could also give rise to secondary risks to any persons who were at the trackside and in the vicinity when collision occurred between the runaway vehicles and the physical protection. Once derailment has occurred, the path taken by a derailing vehicle is unpredictable and could give rise to serious consequences to persons nearby.

- 123 The use of a warning system to warn staff of any approaching runaway vehicles is also not considered to be a practical measure. Such a system would need to be located in a position where it could be heard (assuming it were audible) and to give sufficient time for staff to get clear. As the location of work and vehicles within the work site changed, the warning system would have to be re-located. Work sites have many vehicle movements and if the warning system were not removed each time, there would be false activations leading to a loss of integrity of the system.
- 124 The risk of vehicles running away can, and should, be minimised by a process of risk assessment during the planning of the work. This should take account of the standard hierarchy of risk controls where, for example, a design solution is preferable to a solution that relies on the adherence to a system of work to ensure safety. Where safety relies on a safe system of work that may be subject to human error, it may be appropriate to provide a system of secondary protection so that a single error does not lead to an unsafe situation.

Severity of consequences

- 125 The actual consequences of the accident were limited. However, the runaway salmon wagon – approaching without warning – had the potential to hit any staff working on the line who were unable to get clear in time.

Conclusions

Immediate cause

- 126 The immediate cause of the accident was that the salmon wagon was not left secured on the gradient, and this led to its runaway and ultimate collision with the RRV after the wagon's brakes leaked off (paragraph 97).
- 127 Based on arguments made in paragraphs 111 to 124, the RAIB does not consider that any recommendations are necessary to address the immediate cause because compliance with rules and other instructions would have prevented the accident occurring.

Causal factors

- 128 The causal factor of the accident was unauthorised First Engineering staff coupling and uncoupling vehicles who were neither trained in Module SS2 of the rule book (covering shunting) nor competent to do so. These actions were carried out despite there having been competent EWS staff available (paragraph 106, recommendations 1 and 2).

Contributory factors

- 129 The contributory factors of the accident were:
- The cant compensator system fitted to the Kirow crane was too sensitive and caused spurious alarms to occur (paragraph 107). No recommendation is made regarding this in view of the actions taken by First Engineering (paragraphs 130 and 131).
 - The training given on the correct response to Kirow crane cant compensator alarms was inadequate (paragraph 108, Recommendation 3).
 - There was a miscommunication between the Engineering Supervisor and the Kirow crane crew which led to the Kirow crane crew misunderstanding what the plan was for the Kirow crane following its derailment and acting under their own volition (paragraph 109).
 - The train driver did not apply the handbrakes to the salmon wagon when he left the locomotive and wagon unattended (paragraph 110).

Actions reported as already taken or in progress relevant to this report

- 130 First Engineering Limited raised a *national incident report* (NIR) under Railway Group Standard GE/RT8250 on 31 January 2007. This drew the attention of other operators of Kirow cranes to the consequences that could arise if operators failed to respond correctly to an alarm from the cant compensator system.
- 131 Since the accident at Armathwaite, Kirow have trained crane operators in how to correctly respond to a cant compensator alarm. The system has also been changed to reduce the occurrence of spurious alarms.
- 132 Network Rail led a local investigation into the accident with assistance from EWS and First Engineering Ltd. The report listed six actions to be carried out including the issue by First Engineering Ltd of a safety alert to clarify that coupling and uncoupling duties must only be carried out by competent and certified staff, and that EWS should assess and brief the train driver on the correct procedure for securing trains on site.
- 133 In a memorandum dated 19 February 2007 (see Appendix C), First Engineering issued an instruction to all staff involved with the operation of OTP about the coupling and uncoupling of rail vehicles. The memorandum stated that staff involved with the operation of OTP may only carry out coupling and uncoupling of such vehicles once the vehicle has been uncoupled from a train formation and provided that the staff concerned have competence in the appropriate section of the rule book (module SS2). Only competent staff employed by the freight operating company may couple or uncouple on track plant vehicle(s) to or from a train formation.
- 134 The Kirow crane plan (paragraph 82) has been amended to incorporate the instruction in paragraph 133 above. Staff involved in the operation of the Kirow crane have attended training courses on section SS2 of the rule book.
- 135 EWS has rebriefed the driver on the contents of Traction Digest Advice 83 (paragraph 74) and has also undertaken additional monitoring of the driver's performance while working in possessions.

Recommendations

136 The following safety recommendations are made¹:

Recommendations to address causal and contributory factors

- 1 First Engineering Ltd should instruct their staff under what circumstances they are permitted to couple and uncouple vehicles that make up the consist of Kirow cranes (paragraph 128).
- 2 First Engineering Ltd should ensure that their staff who are permitted to couple and uncouple rail vehicles are competent in the appropriate sections of the rule book (paragraph 128).
- 3 First Engineering Ltd should ensure that operators of Kirow cranes are adequately trained to respond correctly to a cant compensator alarm (paragraph 129).

137 Recommendations 1 and 2 have already been carried out as a result of the action taken in paragraphs 133 and 134.

138 Recommendation 3 has already been carried out as a result of the action taken in paragraph 131.

¹ Duty holders, identified in the recommendations, have a general and ongoing obligation to comply with health and safety legislation and need to take these recommendations into account in ensuring the safety of their employees and others.

Additionally, for the purposes of regulation 12(1) of the Railways (Accident Investigation and Reporting) Regulations 2005, these recommendations are addressed to the Office of Rail Regulation to enable them to carry out their duties under regulation 12(2) to:

- (a) ensure that recommendations are duly considered and where appropriate acted upon; and
- (b) report back to the RAIB details of any implementation measures, or the reasons why no implementation measures are being taken.

Copies of both the regulations and the accompanying guidance notes (paragraphs 167 to 171) can be found on RAIB's web site at www.raib.gov.uk.

Appendices

Glossary of abbreviations and acronyms

COSS

EWS

LUL

NIR

OTM

OTMR

OTP

PICOP

RGS

RIS

RRV

Appendix A

Controller of Site Safety

English Welsh & Scottish Railway

London Underground Ltd

National incident report

On-track machine

On train monitoring recorder

On-track plant

Person in charge of possession

Railway Group Standard

Rail Industry Standard

Road-rail vehicle

Glossary of terms

Appendix B

All definitions marked with an asterisk, thus (*), have been taken from Ellis' British Railway Engineering Encyclopaedia © Iain Ellis. www.iainellis.com.

Air cock	The valve at the end of the brake pipe on a rail vehicle.
Automatic air brake	The continuous brake through a train that will cause a brake application when air pressure in the brake pipe is reduced either by the driver operating the brake or in the event of other circumstances occurring such as a train division.
Brake pipe	In an air brake system, this pipe is pressurised to release the brakes of the vehicles in the train.*
Cant	Cant is the design amount by which one rail of a track is raised above the other rail, measured over the rail centres.*
Chain	One chain equals 22 yards. There are 80 chains in a mile.
Control reservoir	Part of the means by which a distributor regulates pressure to the brake cylinders in response to the changes of pressure in the brake pipe.
Controller Of Site Safety	A safety critical qualification demonstrating the holder's competency to arrange a safe system of work, ie protecting staff working on the line from approaching trains.*
Crane controller	A machine controller responsible for the safe operation of OTP that is carrying out lifting operations.
Detonators	The correct term is railway fog signals; a small explosive device that is fastened to the rail head and exploded by the passage of a railway vehicle.
Direct air brake	The air braking system that applies the brakes to the locomotive (or other rail vehicle) only and not to any attached vehicles.
Distributor	The pneumatic component of the train air braking system that responds to changes in brake pipe pressure and initiates charging of the brake cylinders.
Down line	The track on which trains move away from London or point of lowest mileage.*
Engineering supervisor	The person nominated to manage the safe execution of works within an engineering work site. This includes arranging the marker boards, authorising movements of trains in and out of the work site and managing access to the site by controllers of site safety.*
Engineer's work site	The subdivision of a possession that is delimited by marker boards and managed by an engineering supervisor.*
Groundstaff	Staff employed by a freight operator whose duties include the coupling and uncoupling of rail vehicles.
Keeper bracket	Prevents a bogie becoming free from the Kirow crane's superstructure in the event of derailment.

Machine controller	The person responsible for the safe operation of on-track plant and who must also be a certified COSS.
Marker boards	A device used to delimit the ends of an engineering work site; one being placed on each track at each end of a work site.*
National Incident Report	A report following an incident that is circulated within the railway industry giving technical or operating advice to railway operators.
On Train Monitoring Recorder	A data recorder fitted to traction units collecting information about the performance of the train.
Operating Digest Advice	An immediate instruction to operating staff responsible for shunting or train preparation that is posted at locations where staff book on duty. The contents will in addition be briefed to the staff concerned where the subject matter is of an urgent safety nature.
Outriggers	Beams that extend from the side of a crane used to balance the crane during lifting operations and to increase its lifting capacity.
Overbridge	A bridge that allows passage over the railway.*
Parking brake	On a locomotive or other self-powered rail vehicle, the brake that should be applied when the vehicle is shut down and left unattended.
Possession	A period of time during which one or more tracks are blocked to trains to permit work to be safely carried out on the railway.*
Possession Limit Board	A portable stop sign with a steady or flashing red light located between the rails that denotes the start and the end of a possession.
Rail anchor	A steel clip attached to a vehicle which clamps to the rail and prevents that vehicle running away on a gradient.
Rail slipper	A metal device placed behind a vehicle wheel to prevent the vehicle rolling away.*
Railway Group Standard	Standards within the railway industry that mandate measures in the areas of interface/co-operation between different duty holders.
Road-Rail Vehicle	Any vehicle adapted to run equally well on road and rail.*
Route Availability (RA)	A number in the range zero to 10 that represents the capacity of a bridge or route and the loading produced by a railway vehicle. To pass over a route, the RA number of the route must be greater than or equal to the RA number of a vehicle.
Running pressure	The pressure in the brake pipe that causes the brakes to be released and to be maintained released.
Safety of the line	The condition of freedom from danger to the operators, passengers and traffic of a railway.*
Scotches	A large wooden wedge that can be placed between the wheel of a rail vehicle and the rail head to stop the rail vehicle moving.
Single piped	The provision of a brake pipe within a train to provide both the brake air feed and brake control.

Sleepers	A beam made of wood, reinforced concrete or steel placed at regular intervals at right angles to and under the rails.*
Slewed	In relation to a crane, the movement of the jib to a position away from being parallel to the track centre line.
Supplementary Operating Instructions	Additional instructions to those contained in the railway rule book which are specific to EWS activities and set out detailed operational procedures.
Tare weight	The weight of a rail vehicle capable of carrying a load when it is not carrying any load.*
Thimble	A small wheeled grab that is closed around a loose rail and can then be moved longitudinally while simultaneously lifting the rail.*
Traction Digest Advice	An immediate instruction to drivers that is posted at locations where drivers book on duty. The contents will in addition be briefed to drivers where the subject matter is of an urgent safety nature.
Up line	The track on which the normal direction of trains is towards London or to the point of lowest mileage.*
Vehicle acceptance body	A railway industry body whose role is to ensure that new or modified railway vehicles do not present a hazard.
Weekly operating notice	A document published on a regional basis providing information about engineering work, speed restrictions, alterations to the network and other relevant information to train drivers.*

Memorandum



To: All Staff involved with OTP Operation

CC:

From: Driving Standards

Date:

Re: ATTACHING / DETACHING RAIL VEHICLES.

Staff are reminded that whenever they are required to attach/detach vehicles from other vehicles including the traction then this can only be done by staff who hold the appropriate competency and the task is within the scope of their authority. (RB module SS2 applies)

Procedure:

If the unit/vehicle(s) concerned are in train formation or are ready to be attached to the train on completion of the work then the responsibility lies with the train delivery company for attaching / detaching. However, once the OTP becomes detached then these duties become the responsibility of the OTP operator(s) providing they hold the competence to do so.

Safety Reminder (RB Module SS2)

Attaching / Detaching:

Before any attempt is made to attach / detach vehicles to or from other vehicles the following must be applied:

- the person(s) carrying out the duties has the competence to do so, and
- a clear understanding of what is required has been reached and fully understood by all parties involved. This includes crane / crane controllers, Engineering supervisors and other possession management staff as appropriate.

Attaching:

- The movement is stopped 2 metres from other vehicles until it is established that it is safe to buffer up. Once this is established the movement must be made at extreme caution.
- No attempt is made to go in between until the vehicles have come to a complete stop and you do not remain in between during the ease-up movement
- A hand Danger signal is displayed to the Driver/Operator or the Driver/Operator has been instructed not to make any movement until the task is complete.
- Open the Brake Pipe valve and leave open until the task is complete. This action will stop the driver from charging the BP system thus preventing any movement.
- The attachment can now be made using the correct method and all parking brakes released and scotches removed.
- Before moving off a brake continuity test must be carried out as per RB Module TW3

Detaching:

- Once the train/OTP has been brought to a stop the Driver/Operator must hold the train using the direct air brake. The person responsible for the detachment must apply the vehicle(s) handbrake(s) that are being detached before opening the brake pipe valve to fully apply the air brake. This is to prevent brake gear damage and possible injury when attempting to release the handbrake on vehicles fitted with handbrake levers.
(GO/RT3056/E E6)
- No attempt is made to go in between until the vehicles have come to a complete stop nor must you remain in between vehicles during the ease-up movement
- A hand Danger signal is displayed to the Driver/Operator or the Driver/Operator has been instructed not to make any movement until the task is complete.
- Open the Brake Pipe valve and leave open until the task is complete. This action will stop the driver from charging the BP system thus preventing any movement.
- Disconnect the brake pipe before any other connections and open the brake pipe valve to exhaust all air from the vehicle(s) being left, this also ensures that the brakes are fully applied. The vehicle can now be uncoupled. If you require the driver/operator to squeeze up to allow the coupling to be removed you **MUST NOT** remain in between the vehicles during this process.

Note: Sufficient handbrakes and or scotches must be applied to secure the vehicle(s)/train, applying them at the lower end of the train when on a gradient.

YOU MUST NOT RELY ON THE AUTOMATIC BRAKE TO SECURE A TRAIN OR VEHICLE AFTER DETACHING IT FROM THE TRACTION UNIT OR OTHER HAULING SOURCE (OTP) AND YOU MUST PROPERLY SECURE THE TRAIN VEHICLE(S) BY HANDBRAKE(S) AND OR SCOTCHES.

To be fully competent in these duties you need to be conversant with the following:

Modular Rule book:

- OTP
- SS2
- TW1 (section 1.6 & 6)
- TW3 (section 3 & 4)

GO/RT3056E:

- E.6 & E8

Remember the task is recognised as very high risk, so we need to remain **vigilant, safe** and **alert** and at all times not only for ourselves but everyone around us.

**THINK SAFE! WORK SAFE! STAY
SAFE!**

Driver Standards Manager

This page is left intentionally blank

This report is published by the Rail Accident Investigation Branch,
Department for Transport.

© Crown copyright 2008

Any enquiries about this publication should be sent to:

RAIB	Telephone: 01332 253300
The Wharf	Fax: 01332 253301
Stores Road	Email: enquiries@raib.gov.uk
Derby UK	Website: www.raib.gov.uk
DE21 4BA	